

MODELS-1121, 1122, 1123



All stainless steel construction Safety Pattern Pressure Gauges

APPLICATIONS

Gas and Steam in excess of 25 Bar pressure can represent danger if there is a rupture in the Bourdon Tube measuring this gas. To minimize the danger, gauges in this application should be Safety Pattern type, having solid front between Bourdon tube and dial, safety window and blow-out back to allow any blast to release to the rear of gauge. Although there is not necessarily any great risk in the use of gauges for gases at pressure less than 25 Bar, a blow-out disc should be incorporated and the purchaser should have regard to the nature of the gas and the installation conditions and, if necessary, order a gauge of the Safety Pattern type. [See Page two for more details.](#)

Dry, Liquid Fillable or Pre-Filled. VIBRAGAUGE® Option also available. VIBRAGAUGE® for Dampening of vibration & pulsation without liquid filling. With liquid-filled case for applications with high dynamic Pressure pulsations or vibration.

STANDARD SPECIFICATION

Petro-Chemical Safety Pattern Gauge with Baffle Wall (Weatherproof to IP66)

Model-1122 Direct Mounted

Sizes

63, 100 and 150 mm

Case/ Bezel

316 Stainless Steel

Socket & Element

316 Stainless Steel

Movement

Stainless Steel Construction

Blowout Protection

S3 Safety Pattern with Baffle Wall and Blow-out Back

Dial

White Anodised Aluminium (Black Printing)

Pointer

Black Aluminium

Window

Laminated Safety Glass

Traceability

All instruments are individually calibrated and have an unique Serial Number.

Certification available on request

- Certificate of Conformity Traceable to National Standards
- Group Certification (Pressure Test Calibration Statement)
- Point to Point Test Certificate
- BS EN 10204 3.1 Material Certification

Safety

All units are manufactured to comply with EN 837-1, S3 Safety Pattern specification and other regulatory standards including PED 2014/68/EU.

Installation instructions

Refer to EN 837-2 and our [Guidance On Use of Equipment](#) data sheet.

Accuracy class

	ACCURACY CLASS EN837-1 (Optional)		Higher Pressure
	0 - 600 bar	>600 - 1600 bar	>1600 - 2500 bar
63mm	1.0	1.6 *	N/A
100mm	1.0 (0.6)	1.0	1.6
150mm	1.0 (0.6)	1.0	1.6

0.5% Accuracy on request (Consult Sales)

Higher Ranges on request (Consult Sales)

Over-pressure

0 - 100 bar	>100 - 600 bar	>600 - 1600 bar	>1600 - 2500 bar
1.25 x FSD	1.15 x FSD	1.10 x FSD	1.10 x FSD

Scale Range

Vacuum / Compound to -1 to 0 to -1 to 24 bar

63mm gauge 0 to 1400 bar *

100 & 150mm gauges 0 to 2500 bar

Or other equivalent units of pressure or vacuum

PED 2014/68/EU limits, GAS Group.1 <1000 bar, GAS Group.2 <3000 bar

Pressure Connection Thread

1/8", 1/4", 3/8", 1/2" NPT, BSP, BSPT (See High Pressure Options)

MAX PRESSURE EN 837-1			
THREAD EN837	NPT (316ss / Monel)	BSP (316ss / Monel)	BSPT (316ss / Monel)
1/8"	400 bar	400 bar	400 bar
1/4"	1000 bar	1000 bar	1000 bar
3/8"	1000 bar	1000 bar	1000 bar
1/2"	1000 bar	1600 bar	1000 bar



Model-1121 Surface Mounted (Bottom Connection)

Model-1122 Direct Mounted (Bottom Connection)

Model-1122BC Direct Mounted (Rear Connection)

Model-1123 Flush Mounted Screw Fixing (Rear Connection)

[See Page-2 for dimension](#)

Operating Temperature Range EN837

-20° to 60°C (-4°F to 140°F)

Options for lower/higher operating ranges (Contact Sales)

Temperature Error

Additional error when temperature changes from reference

Temperature of 20°C (68°F) ±0.4% for every 10°C (18°F) rising or Falling % of span

Optional Extras

- Micro adjustable pointer /Black finish
- Optional dial materials & Custom markings
- Monel according to ISO 15156 / NACE MR-01-75 wetted parts
- Other pressure connections (Including high pressure)
- Perspex window
- Orifice Restrictor Screw (standard Ø0.9mm, Ø0.4mm on request)
- Customer logo printed on dial
- Liquid filled / Suitable for liquid filling
- Nitelitegag® (See data sheet)
- Vibragauge® (See data sheet)
- Snubbagaug® (See data sheet)
- Fitted with electrical contacts (See data sheet)
- Gauge over-pressure up to 130% of FSD

Further options on request

Available with a wide range of accessories

Syphons, Snubbers, Overrange gauge protectors, Valves, Manifolds, Diaphragm seals, Swivel adaptors, etc ensures that STEWARTS can provide you with the right product to suit any individual application or requirement.

High Pressure Options Available

GAUGE	HIGH PRESSURE THREAD OPTIONS (Up to 2500 bar)					
	TUBE MP (Up to 20 ksi)			TUBE HP (Up to 36 ksi)		
	1/4"	3/8"	9/16"	1/4"	3/8"	9/16"
63mm	M	M				
100mm	M/F	M/F	M	M/F	M	M
150mm	M/F	M/F	M	M/F	M	M

Ordering Parameters, Please state the following: SIZE, MODEL NO, SCALE RANGE, CONNECTION, PRESSURE MEDIUM & OPTIONAL EXTRAS

MODELS-1121, 1122, 1123



All stainless steel construction Safety Pattern Pressure Gauges

Full safety pattern gauges as defined by the European Standard EN837-1 differ from standard pressure gauges in several different ways and offer significantly greater protection for the operator in the event of a catastrophic failure of the pressure system. These added safety features include:

- Internal Solid Baffle Wall
- Complete Blow Out Back
- Laminated Safety Glass Window

The internal baffle wall is welded around the internal diameter of the case behind the dial. Its purpose is to ensure any rapid pressure release from a failure of the bourdon tube is directed away from the front of the gauge preventing debris and process media being sprayed at high velocity in the direction of the operator. In the event of such failure, the blow out back which is designed to cover the full diameter of the case will open allowing the expanding pressure pulse to vent from the back of the gauge into a safe area away from the operator. The laminated safety glass window will not splinter in the event of a failure of the pressure chamber.

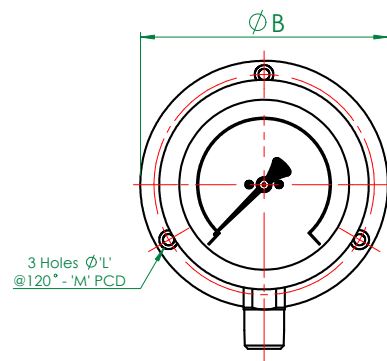

MODEL - 1121
Surface Mounted

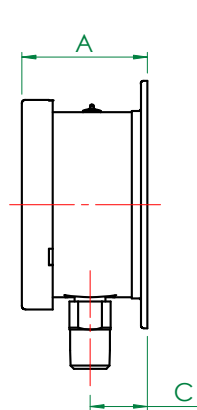

MODEL - 1122
Direct Mounted (Standard)

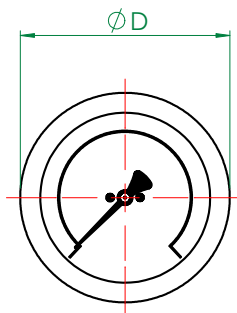
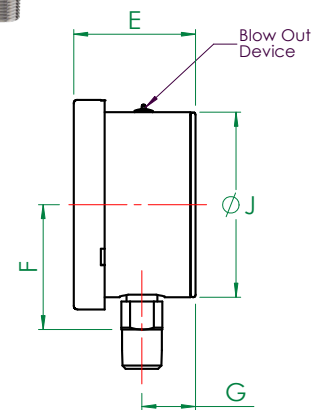
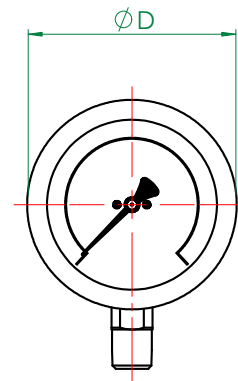

MODEL - 1122BC
Direct Mounted (Back Connect)

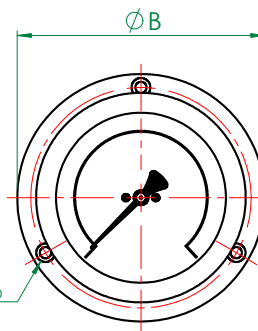
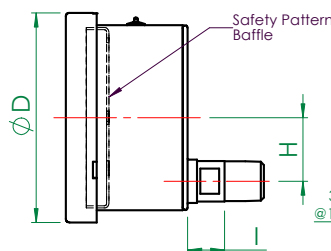

MODEL - 1123
Flush Mounted - Screw Fixing

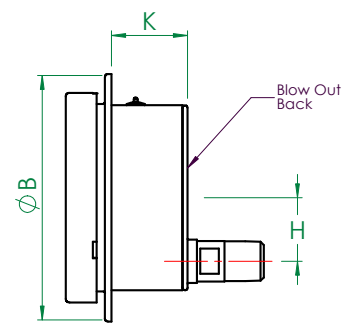

Surface mounted gauges should be fitted with distance pieces of not less than 3/4" (20mm) long to allow them to be mounted away from wall or panel.

General Arrangement Dimensions in mm, tol' ± 1mm														
Ø mm DIM	A	B	C	D	E	F	G	H	I	J	K	L	M	CUT OUT
63 (2½")	42.4	85.2	20	68.4	42.6	41.8	20.4	18	13.6	62	24.6	3.8	75	66
100 (4")	67.2	132.5	30.7	112.2	65.2	66.9	28.7	34	19.8	99	40.7	6	118	106
150 (6")	67.7	186	31.2	161.7	65.7	92.1	28.7	34	19.8	148	37.7	5.8	168	153

STEWART-BUCHANAN GAUGES LTD

Sales Office & Manufacturing Facility - 7 Garrell Road, Burnside Industrial Estate, Kilsyth, Glasgow G65 9JX, SCOTLAND
Tel: +44 (0)1236 821533 | Fax: +44 (0)1236 824090 | E-mail: sales@stewarts-group.com | Web: stewarts-group.com

